



RACING TOUR

PROVISIONAL 2018 GC32 RACING TOUR RULES

30th OCTOBER 2017

VERSION 1.0

1. Organisation

- 1.1 The 2018 GC32 Racing Tour is managed by the GC32 Event LLC (“GCE”) subsidiary of the GC32 International Class Association (“ICA”). The GCE appoints Yacht Clubs, Marinas or Event Agencies to organise and fund GC32 events. For each of its events the GCE appoints a local Organiser with whom the GCE coordinates the organisation of that event. GCE also manages the relations with any sponsors that the 2018 GC32 Racing Tour enters into agreement. For the GC32 Class Championship the ICA appoints directly the local Organiser and manages all event relations.
- 1.2 The 2018 GC32 Racing Tour is an annual competition of five official ICA and GCE events listed in Clause 3.1 of these rules.
- 1.3 Each Organiser shall sign an Event Agreement with the ICA or GCE and follow the Event guidelines and regulations issued by the ICA and GCE, including Event Communication Briefing, Sponsorship Regulations and any other regulations issued by the ICA and GCE in respect of Event Organisation.
- 1.4 The boats sailed in the 2018 GC32 Racing Tour are GC32 One Designs.

2. Rules

- 2.1 The 2018 GC32 Racing Tour will be governed by:
- a) The rules as defined in the World Sailing Racing Rules of Sailing (RRS 2017-2020) “Fast Boats Edition”.
 - b) The GC32 Class Rules and interpretations.
 - c) The 2018 GC32 Racing Tour Rules.
 - d) The Notice of Race (NOR) of each individual event.
 - e) The Sailing Instructions (SIs) of each individual event.
- 2.2 The official language of the 2018 GC32 Racing Tour shall be English.
- 2.3 Any modification of these Rules will be sent by e-mail to teams with boats registered in the 2018 GC32 Racing Tour and the Organising Authorities of the individual events.

3. Schedule

- 3.1 2018 GC32 Racing Tour schedule (Official practice and race days):
- | | |
|------------------------|-------------------------------------------------|
| May 23rd – 27th | GC32 Class Championship / Riva del Garda, Italy |
| June 26th – 30th | GC32 Villasimius Cup / TBC |
| July 31st – August 4th | 37 Copa del Rey / Palma de Mallorca, Spain |
| September 12th - 16th | TBA |
| October 10th – 14th | TBA |
- In case of an event being cancelled, the GCE reserves the right to substitute the event with another held at an alternative venue.
- 3.2 Event schedule:
The official schedule for each event will be issued with the NOR of that event. The provisional schedule for events is as follows:
- 1 official arrival day (craning of containers)
 - 1-2 free practice days (depending on the venue)
 - 1 official practice day with race management team
 - 4 days of racing
 - 1 official departure day (craning of containers)

4. Entries

- 4.1 The 2018 GC32 Racing Tour competitors shall comply with the following requirements:
- 1) The team owner shall be a fully registered member of the GC32 Int. Class Association.
 - 2) All Class regulations, including Class Rules (CR), Class Constitution and 2018 GC32 Racing Tour Rules.
 - 3) The World Sailing Regulation 19 – Eligibility Code. Each crewmember must have a World Sailing sailor ID and be registered with a MNA.
 - 4) Each boat shall have a valid measurement certificate.
 - 5) Each team shall hold a valid 2018 GC32 Racing Tour license (apply to christian@gc32racing.com).

- 6) Submit the signed entry forms for the GC32 Class Championship 2018 and GC32 Racing Tour 2018 (downloadable on www.gc32racingtour.com/onb and www.gc32.org/onb) before the 15th of December 2017.
 - 7) Pay the GC32 Racing Tour entry fee of € 40'000 and the € 10'000 for the GC32 Class Championship before the 31st of December 2017.
 - 8) Late entries may be accepted, but in such cases an additional late entry penalty fee may be incurred.
- 4.2 Single event entries for the 2018 GC32 Racing Tour are possible. Teams have to fulfill all requirements stated in clause 4.1 (1-6). The entry form must be submitted no later than 6 weeks prior to the start date of the event. The single event entry fee is €11.500 (to be paid no later than 4 weeks prior to the start date of the event)
- 4.3 The two respective entry fees for the 2018 Class Championship and 2018 GC32 Racing Tour are based on the 2017 budget and includes:
- Support from the GC32 Racing Tour management team
 - Mooring or berthing at the events during the official event period
 - Craning at the events following the official schedule
 - Professional Race Management throughout each event
 - Video, photos, live on the water blogging and social media
- 4.4 Hospitality will be based on sponsors and team requirements. Costs will be covered by sponsorship fees and/or the entry fees of the teams.

5. Courses

- 5.1 Courses shall be windward-leeward with upwind or reaching starts and reaching or downwind finishing legs between set marks. The length of the courses will be set by the Race Committee dependent upon the size of race area and the wind strength and direction.
- 5.2 Coastal Courses are round the cans, non-windward-leeward races identified in the Sailing Instructions for each event. The length of the courses will be set by the Race Committee according to the race area and wind and sea conditions.
- 5.3 Time Trial/Speed runs, typically involving two reaching legs with a gybe..

6. Sails and sail limits

- 6.1 As per the Class Rules, a boat can register a maximum of 5 sails for the 2018 GC32 Racing Tour. These sails shall be a mainsail, a light jib, a heavy jib and two gennakers.
- 6.2 Each boat shall register their sails with the GCE before the start of their first event of the 2018 GC32 Racing Tour, except the 2nd gennaker, which may be added at any time during the 2018 GC32 Racing Tour season.
- 6.3 Only class legal sails produced by the licensed manufacturer from the year 2016 and 2017 can be registered.
- 6.4 In the case of irreparable damage to a sail, or non-intentional loss, a request for replacement may be made to the GCE.

7. Onboard Hospitality

- 7.1 Onboard Hospitality approval:
All owners and teams taking part in the 2018 GC32 Racing Tour agree to allow media and guests onboard during the series. The 2018 GC32 Racing Tour aims to have onboard guests only in training sessions, Time Trials / speed runs or dedicated 'onboard guest periods'.
- 7.2 When guests sail onboard, there will never be more than one at a time per boat and either all boats shall carry a guest, or none shall carry a guest. These guests shall not contribute to the racing of the boat in any way.
- 7.3 Hospitality Coordination:
At each event, the local event Organiser will appoint a person, who will assist the GCE in managing the hospitality program, including spectator boats and the onboard hospitality program. It is the responsibility of the Organiser to use appropriate equipment in order to transfer guests on and off the boats safely and to maximise the safety of their sailing experience.

- 7.4 Allocation of onboard guest hospitality slots:
Onboard slots shall be allocated by the GCE, in cooperation with the local event Organiser. Owners who intend to invite their own guests shall liaise with the GCE and pre-book their slots at least seven days before the start date of each event, providing at the same time, the name of each guest and the date they will be onboard. The GCE is not obliged to accept all team guests. Slots not used by a team may be allocated to another party. In general, slots shall be allocated 50% for team guests and 50% for GCE guests.
- 7.5 Equalising weight of guests while racing:
If guests are onboard during official racing, the guest on each boat will be weighed and corrector weights may be used to equalise the weight of guests between boats.
- 7.6 Onboard guest safety:
Onboard guests will be required to wear buoyancy aids, shoes and helmets while sailing on board the GC32s. Buoyancy aids and helmets will be supplied by the GCE. Onboard guests shall be of good health and are required to sign a liability waiver form. Guests under the age of 18 will need a written parental approval before being permitted to sail. Children or guests that do not fit the GCE supplied buoyancy aids and other safety equipment will not be allowed as onboard guests. Before racing on the GC32s, all onboard guests will attend a mandatory safety briefing. Whilst onboard a designated member of the racing crew shall be the contact person for the guest. Guests shall be seated only in the one designated guest position on the forward trampoline on the starboard side. The designated guest position shall be marked in a contrasting colour to the trampoline and this position will be equipped with a handle for the guest to hold on to.
The Race Committee has the right to advise that no guests shall be carried onboard the GC32s should it feel that conditions may compromise the safety of the guests.

8. Scoring system

- 8.1 Event results:
- 8.1.1 World Sailing RRS Appendix A shall apply.
 - 8.1.2 For Event 1 (GC32 Class Championships, Riva) of the 2018 GC32 Racing Tour eligible boats will be scored, excluding non-eligible boats, and awarded a ranking for the event.
 - 8.1.3 Coastal races, if any are held, will be scored in the same way as windward leeward races.
 - 8.1.4 Time Trials / Speed Runs, if any are held, will be counted as "special event" and will not score in the event results.
- 8.2 2018 GC32 Racing Tour annual championship ranking:
- 8.2.1 After each event, each Team will receive the number of points corresponding to their final ranking at that event. The final season's ranking will be a sum of all the points collected during the five events of the 2018 GC32 Racing Tour.
 - 8.2.2 A Team must compete in a minimum of three events on the GC32 Racing Tour to qualify for a ranking on the final leaderboard at the end of the season.
 - 8.2.3 A team that competes in three regattas, but does not take part in an event shall receive the following number of points: Number of boats who have completed three or more events at the end of season plus 1 point.. Teams which do less than three GC32 Racing Tour events will not be eligible for a overall ranking in the 2018 GC32 Racing Tour.
 - 8.2.4 The GCE will issue the official on-going 2018 GC32 Racing Tour ranking according to 8.2.1..
 - 8.2.5 In case of a tie, the team with the better ranking in the last 2018 GC32 Racing Tour event will be ranked higher..
 - 8.2.6 After the last Event, the GCE will issue a final 2018 GC32 Racing Tour rankings. The team with the lowest score will be the winner of the 2018 GC32 Racing Tour.

8.3 Owner-driver ranking

In addition to the GC32 Racing Tour ranking for the year and for each event, there will be a separate ranking for boats with an owner-driver. The winning owner-driver team will be awarded a trophy for each event on the 2018 GC32 Racing Tour as well an annual prize based on cumulative results from each 2018 GC32 Racing Tour event.

An 'owner-driver' is defined as:

- (a) Being classified Group 1 under the World Sailing Sailor Classification Code.
- (b) In the last six years having only been classified as Group 1 (or would have been classified as such had a classification been held).

An owner-driver cannot be a:

- who has completed in the sailing events at the Olympic Games, Volvo Ocean Race or in an America's Cup or challenger selection series for the America's Cup within the last five years.
- sailor who has been in the top 50 of the World Match Racing Rankings for the past five years.

If a team's owner-driver is absent for any regatta or race then the team must appoint a stand-in owner-driver fulfilling the above criteria and seek confirmation of the acceptability of his replacement from the 2018 GC32 Racing Tour Management (email: christian@gc32racing.com) before the start of the regatta or race. If for any races, the owner-driver criteria is not fulfilled then the team in question will be scored DNF ("Did Not Finish").

The owner-driver ranking will be based on scores taken directly from the overall ranking (ie it will not have its own low-points scoring system). Clauses 8.1 and 8.2 will also apply to the owner-driver ranking.

9. Prizes

9.1 The final 2018 GC32 Racing Tour prize giving will take place at the end of the last event of the season.

9.2 At each GC32 Racing Tour event a prize giving will take place for that event.

10. Branding

10.1 Team, Class and Organiser signage: the branding on boats shall be positioned in accordance with Appendix 1, 2 and 3 of the 2018 GC32 Racing Tour Rules.

It is the responsibility of the Owner to ensure that his or her vessel is branded according to the GC32 Racing Tour Rules. The GCE may change the branding displayed in the Appendix 1, 2 and 3, upon confirmation of Class Sponsorship and provided that a majority of owners vote to allow the change.

10.2 In case of a breach of 2018 GC32 Racing Tour rule 10, the GCE shall advise a team to apply the rule or it will be penalised without a hearing, changing RRS 63.7. A second breach of the rule may lead to the exclusion of the team from an event. Additional breaches of the rule may lead to the exclusion of the team from the 2018 GC32 Racing Tour with no possibility of any reimbursement of entry or membership fees.

10.3 The class sponsor branding, according to GC32 Racing Tour Rules Appendix 1, 2 and 3, including stickers, flags, boom cover, will be provided by the GCE. The competitors shall be responsible to keep them clean and tidy, as per Appendix 4.

11. Communication

11.1 Every Team shall participate in communication and promotional events, as requested by the Organiser and/or the GCE. At least one member of each team shall attend all of these events. All skippers must attend all press conferences. All crew members must attend prize giving ceremonies.

11.2 During the 2018 GC32 Racing Tour events, boats may be requested to carry a GPS tracker and/or a camera provided by the Organiser. The GPS tracker/cameras enable the

transfer of performance information to assist the media and spectators in following the racing. Teams are responsible for this equipment while it is in their possession.

- 11.3 In the case of a serious emergency involving personal injury, there will be no communications by the teams nor their media representatives, the Organising Authority or GC32 Racing Tour media team until a communication plan has been mutually agreed between the relevant parties. In the event of a routine incident, such as a man overboard or a capsize, once the Safety Officer and Principal Race Officer have ascertained that everyone involved in the incident is safe, all parties will be free to communicate the incident.

12. Request for redress and disputes

- 12.1 Redress Limitation: a boat may only request redress when racing at an event; redress may be granted for this event only and shall not be given for a greater number of races than half of the races sailed at the event.
- 12.2 2018 GC32 Racing Tour Rules disputes:
Issues or disputes regarding the 2018 GC32 Racing Tour rules shall be sent in writing to the GCE Office. The GCE will study the request and provide competitors with an official answer.
- 12.3 By taking part in the 2018 GC32 Racing Tour, an owner commits to use no other rights of appeal other than those described in the World Sailing RRS and the GC32 Racing Tour Rules.

13. Logistic and assistance

- 13.1 Each team must have its own RIB as a support boat of an adequate size and engine power to right a capsized boat. The maximum size of the support boat must not exceed 12m. No more than one support boat per team is allowed. All support boats shall be clearly identified and registered at each event.

14. Insurance and disclaimer of liability

- 14.1 For each claim, every boat must have a minimum annual third-party insurance of 3 million Euros. It is the owner or owner's representative's responsibility to ensure that the insurance is in place and is adequate.
- 14.2 This insurance must also include third-party cover for all operations carried out by a team ashore, beyond those covered by the team's car insurance.
- 14.3 Every owner or owner's representative must provide physical proof to the GCE of this insurance cover as stipulated in 14.1 and 14.2.
- 14.4 Competitors participate in the Events and in the GC32 RACING TOUR entirely at their own risk (see RRS Rule 4, 'Decision to Race'). The Organising Authority, its employees and subcontractors, race officials, umpires and the GCE will not accept any liability for material damage or personal injury or death sustained in conjunction with or prior to, during, or after the Events on the GC32 RACING TOUR.

Appendix 1: Afloat branding

Signage position

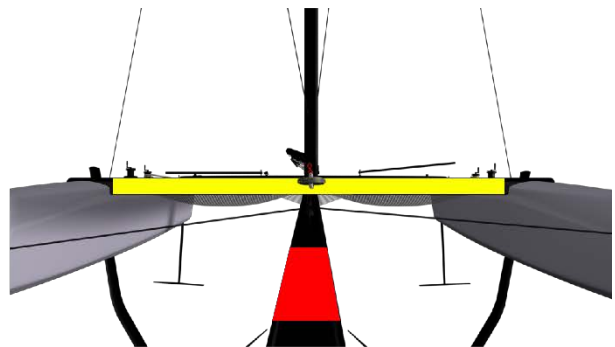
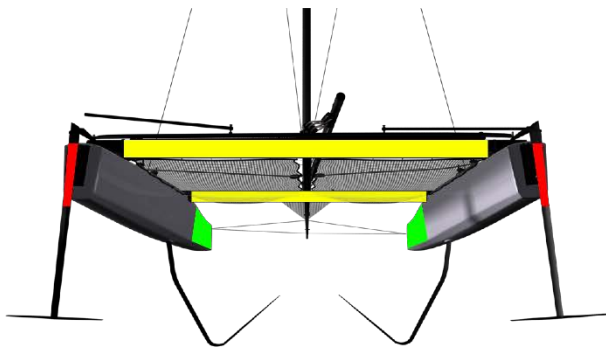

Signage positions (continued)

TEAM Sponsors

- Hull: position starting aft of the first 25% of bow to the front edge of the back beam
- Mainsail: GC32 class logos and sail numbers must comply with Class Rules. Otherwise there is no restriction on mainsail branding
- Headsail: no restrictions on headsails
- Gennakers: no restrictions on gennakers
- Beams: no restrictions on the beams
- Boom: no restrictions on the boom
- No restrictions on crew branding
- National flag

VENUE Sponsors

The following must be reserved for Class sponsor branding:

- Bow: the forward 25% of the inside hulls

TOUR Sponsors

The following must be reserved for Tour sponsor branding:

- Bow: the forward 25% of the outside of the hulls
- Rudders: all area above the waterline
- Gennaker pole
- Hull: from the front edge of the back beam to the back end of the hull on both sides
- Mast

CLEAR areas – not for use

- Standing rigging
- Any area not mentioned above

Appendix 2: Ashore branding

Signage position and dimension

TEAM Sponsors - Team flags overall area 80 x 600 cm

- Forestay flags: overall dimension 80 x 600 cm, positioned 100 cm from the jib tack fitting

VENUE Sponsors – Organiser flags overall area 80 x 200 cm

- Forestay flags: overall dimension 80 x 200 cm, positioned above Team Flags

TOUR Sponsors – Tour flags overall area 80 x 400 cm

- Forestay flags: overall dimension 80 x 400 cm, positioned above Organiser Flags

CLEAR areas – not for use

- Mast
- Any area not mentioned above

Appendix 3: Clothing branding

Signage position and dimension

- Space for Tour Title Sponsor Logo (6cm wide) on right or left arm of team clothing
- All other areas free to the team

Appendix 4: Owners and Skippers liability

- Teams are responsible to comply with the sponsorship and signage regulations contained in the GC32 Racing Tour 2018 Rules and any and all regulations issued by the Class
- Teams may submit a diagram of their Branding layout to the GCE for approval
- Branding shall be kept in a clean and tidy condition and stickers shall be properly applied and maintained. Teams shall maintain the marketing material provided by the GCE and the Organiser
- Competitors attention is drawn to Rule 10 and Appendix 1-3: if the branding does not comply with the regulations:
- The GCE Office may penalise any non-complying team

Appendix 5: Onboard guest position

